

# Design and Development of an Enhanced Modular Multilevel Converter Using Advanced Predictive Control for Motor Drive Systems

Kishor Parapelly<sup>1</sup>, C.Mahalakshmi<sup>2</sup> and Venu Madhav G<sup>3</sup>

<sup>1</sup>Research Scholar, Department of Electrical Engineering, Faculty of Engineering and Technology, Annamalai University, Annamalai Nagar, Chidambaram, 608002, Tamil Nadu, India

<sup>2</sup>Associate Professor, Department of Electrical Engineering, Faculty of Engineering and Technology, Annamalai University, Annamalai Nagar, Chidambaram, 608002, Tamil Nadu, India

<sup>3</sup>Associate Professor, Department of Electrical & Electronics Engineering, Anurag University, Hyderabad, Telangana, India

\*Correspondence: [parepellykishore@gmail.com](mailto:parepellykishore@gmail.com);

**ABSTRACT-** This paper presents the design and implementation of a Modular Multilevel Converter (MMC) integrated with a motor drive system. The MMC topology offers numerous advantages such as improved voltage waveform quality, reduced harmonics, and enhanced reliability, making it an attractive choice for high-power motor drive applications. The proposed system architecture is modular in nature, facilitating scalability and flexibility to meet varying power requirements. Design considerations including sub module configuration, control strategies, and modulation techniques are discussed in detail. Furthermore, the practical implementation aspects of the MMC with the motor drive system are presented, addressing challenges related to hardware realization, control algorithm implementation, and performance evaluation. Experimental results validate the effectiveness of the proposed system in achieving high-quality output voltage waveforms and efficient motor operation across a range of operating conditions. Overall, the presented design and implementation offer a promising solution for high-power motor drive applications, leveraging the benefits of modular multilevel converter technology.

**Keywords:** Power electronics, Modular multilevel converter, Modern predictive control, Motor drive.

## ARTICLE INFORMATION

**Author(s):** Kishor Parapelly, C. Mahalakshmi, and Venu Madhav G;

**Received:** 16/05/24; **Accepted:** 07/11/24; **Published:** 15/12/24;

**E- ISSN:** 2347-470X;

**Paper Id:** IJEER240407;

**Citation:** 10.37391/ijeer.120427

**Webpage-link:**

<https://ijeer.forexjournal.co.in/archive/volume-12/ijeer-120427.html>

**Publisher's Note:** FOREX Publication stays neutral with regard to jurisdictional claims in Published maps and institutional affiliations.



## 1. INTRODUCTION

Power electronics technology is vital in several facets of contemporary life and industry. Power electronics facilitate the efficient transformation, regulation, and administration of electrical energy. It enhances the creation of energy-efficient systems by optimizing power transmission and reducing losses in many applications. Power electronics converters play a crucial role in the integration of sustainable energy sources, such as solar, wind, and hydropower, into the grid. They facilitate the transformation of fluctuating and frequently uncertain sustainable energy sources into steady and synchronized AC power, allowing them to seamlessly integrate into the current power system.[1].

In industrial settings, power electronics technology is widely used for motor drives, variable speed control systems, and

power supply units. It enables precise control of motor speed and torque, leading to improved process control, energy savings, and enhanced productivity in manufacturing and automation applications. Power electronics devices offer flexibility in power system design and operation by enabling the integration of distributed energy resources, energy storage systems, and demand-side management strategies. They facilitate dynamic control and optimization of power flow, contributing to grid resilience, reliability, and adaptability to changing demand patterns. Power electronics technology plays a vital role in advancing energy efficiency, sustainability, and technological innovation across diverse sectors, making it indispensable in the modern era [2].

### 1.1 Power electronics technology in electrical power systems

Power electronics technology is crucial for improving the efficiency, reliability, and flexibility of electrical power systems. It allows for the integration of sustainable energy sources, enhances grid stability, and supports the transition towards a more sustainable and resilient energy infrastructure.[3].

Power electronics converters play a vital role in the integration of sustainable energy sources like solar photovoltaic (PV) systems, wind turbines, and hydroelectric generators into the grid. These converters effectively convert the fluctuating DC power from sustainable sources into steady AC power, enabling

synchronization with the electrical grid. They offer the ability to manage the flow of electricity in both directions, regulate voltage, and synchronize operations, allowing for smooth integration of distributed energy resources (DERs) with the current grid architecture.[4].

HVDC transmission systems employ power electronic converters to convert alternating current (AC) power into direct current (DC) for efficient long-distance transmission, resulting in reduced energy losses and enhanced control capabilities. HVDC technology allows for effective transmission of electricity between asynchronous AC grids, enabling the interchange of energy between locations with varying frequencies or voltage levels. VSC-based HVDC transmission systems and Flexible AC Transmission Systems (FACTS) utilize power electronic converters to provide fast and precise control of voltage and power flow. VSC technology offers advantages such as modular design, improved transient response, and reduced harmonic distortion compared to traditional line-commutated converters. Power electronics technology is extensively used in motor drives, variable speed control systems, and industrial automation applications. It enables precise control of motor speed, torque, and efficiency, leading to energy savings, improved process control, and enhanced productivity in manufacturing and industrial processes [5].

## 2. PROPOSED TECHNIQUE

A Modular Multilevel Converter (MMC) is an advanced type of power converter that has become increasingly popular for high-voltage direct current (HVDC) transmission systems and for interfacing sustainable energy sources with the grid. The MMC consists of a large number of sub-modules, each containing a small voltage source (which can be either a capacitor or a small battery) and power electronics switches (IGBTs or MOSFETs) that can generate voltage levels of either polarity or zero. These sub-modules are connected in series to form each arm of the converter, allowing it to synthesize a staircase voltage waveform that closely approximates a sine wave[6].

MMCs produce high-quality output waveforms with reduced harmonic distortion compared to traditional converter topologies. This is especially important for grid-connected applications where maintaining power quality is crucial. The modular structure of MMCs allows for easy scalability to accommodate varying power levels. Additional sub modules can be added or removed as needed, making MMCs versatile for different system configurations and requirements. MMCs offer high efficiency levels, particularly at partial load conditions. This results in energy savings and reduced operating costs over the lifetime of the system, making MMCs economically advantageous for long-term applications[7].

MMCs employ capacitor voltage balancing techniques to ensure uniform voltage distribution among sub modules. This helps to prolong the lifespan of components and improve overall system performance by reducing stress on individual components. Compared to other converter topologies, MMCs operate at lower switching frequencies, leading to reduced

switching losses and electromagnetic interference (EMI). This contributes to higher efficiency and reliability of the converter system. MMCs offer advanced grid integration capabilities and precise control over power flow, voltage regulation, and reactive power compensation. They can help optimize power system operation, enhance grid stability [8].

MMCs provide the ability to effectively manage high voltage levels. They are particularly suitable for use in applications such as high-voltage direct current (HVDC) transmission, grid-connected sustainable energy systems, and high-power motor drives. MMCs have a more efficient and lightweight structure in comparison to conventional converter topologies because they use modular submodules. These characteristics make them well-suited for applications that prioritize space and weight limitations. Modular multilevel converters are highly suitable for various applications in the power electronics area, such as integrating sustainable energy, transmitting HVDC, driving motors, and connecting to the grid, among others. This paper discussed several applications of motor drives.[9].

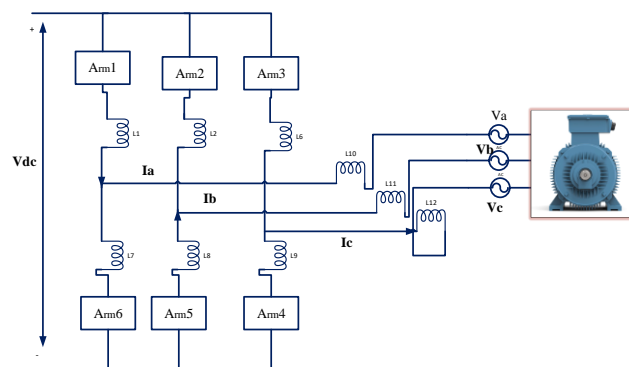

**Figure 1.** Schematic diagram of MMC

Figure 1 depicts to be a schematic of a three-phase inverter with six switches (which could be transistors or IGBTs), commonly referred to as an ARM in power electronics terminology. This inverter converts a DC input voltage ( $V_{DC}$ ) into an AC output voltage ( $V_{ac}$ ), which can be used to drive three-phase motors or to feed power into an AC grid[10].

The three arms on the top (ARM1, ARM2, ARM3) correspond to one set of switches for each phase, and the three arms on the bottom (ARM4, ARM5, ARM6) correspond to another set, with each pair of arms controlling the flow of current to one phase of the output. The inductors (L) are typically used to filter out high-frequency components from the switching actions and ensure a smoother AC output waveform[11].

The inverter operates by rapidly switching each ARM on and off in a specific sequence to synthesize a three-phase AC waveform from the DC supply. The actual AC output voltage and frequency can be controlled by adjusting the timing and pattern of these switching actions[12].

### 2.1 Block Diagram of MMC

This figure 2 depicts the block diagram of a Modular Multilevel Converter (MMC), which is a complex type of power converter

used for converting electrical power. The MMC comprises numerous submodules that are controlled in such a way as to produce the required AC waveform from a DC source[13].

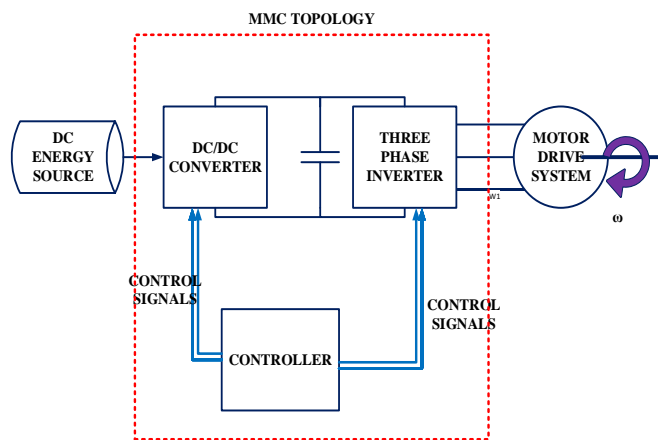

**Figure 2.** Block diagram of MMC

A Modular Multilevel Converter (MMC) is a type of converter that uses a series of submodules per phase to synthesize the desired voltage waveform. A basic block diagram of an MMC might include the following components:

- **Submodules (SMs):** These are the building blocks of an MMC. Each submodule typically contains a small energy storage component (like a capacitor) and switching elements (like IGBTs or MOSFETs). The submodules are connected in series to form a chain, or "arm," for each phase of the converter[14].
- **Arm Inductors:** These are inductors placed in series with the arms to limit the rate of current change and filter out high-frequency components[15].
- **DC Supply (or DC Link):** This is the source of DC power for the converter. It often includes a positive and negative rail.
- **AC Terminals:** These are the output terminals where the synthesized AC voltage is provided to the load or grid.
- **Control System:** The control system is a crucial part of the MMC, which includes several components:
  - A controller for maintaining the capacitor voltage balance across all submodules.
  - A current controller to ensure that the output currents are at the correct amplitude and phase in relation to the AC voltage.
  - A circulating current controller to minimize any circulating currents within the converter.
  - A modulation controller that determines the switching states of the submodules to synthesize the AC output waveform.
- **Communication System:** Since each submodule's switching state needs to be individually controlled, a communication system is often necessary to send the control signals from the central controller to each submodule[16].

The complexity of the MMC design and control is due to the large number of submodules that must be precisely controlled to achieve high-quality power conversion with the benefits of modularity, scalability, and high efficiency. The MMC is especially popular in applications of large motor drives.

## 2.2 Control Scheme

Figure 3 depicts A modular multilevel converter (MMC) typically employs a complex control scheme due to its intricate structure and multiple levels of operation. The control scheme of an MMC usually involves several hierarchical layers, each responsible for different functions[17].

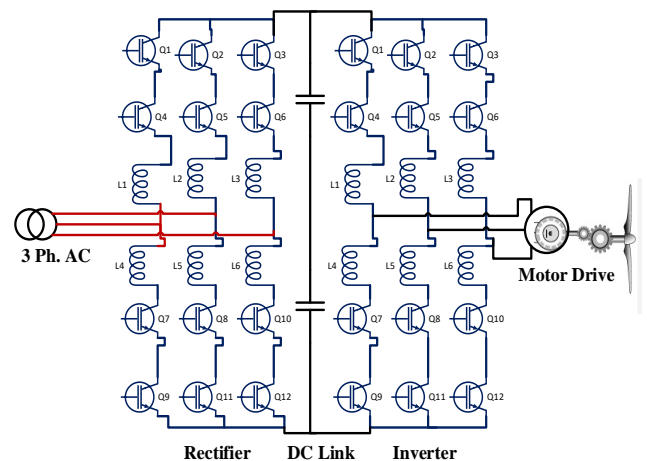

**Figure 3.** Control structure of MMC

In motor drive applications, alterations to the capacitor voltage control approach are essential when the frequency varies. For instance, it may need to be divided into three separate strategies for current and voltage injection, depending on motor speed, or regulating the AC and DC components within the arms independently through unsymmetrical arm control. While the former method is simpler to implement, it faces interruptions in operation when the control strategy changes. On the other hand, the latter approach offers improved performance at the expense of increased complexity. Model predictive control (MPC) stands as a straightforward yet potent alternative for controlling power converters, suitable even in scenarios of varying AC frequency[18].

Although MPC offers rapid performance, its drawback in MMC applications stems from the abundance of possible switching states, necessitating substantial processing power. To address this issue, an efficient solution has been proposed: modulated MPC. This method employs continuous optimization, with the resultant modulation index subsequently modulated using phase-shifted pulse-width modulation (PWM). The modulated MPC approach not only cuts down on processing time but also minimizes steady-state error. By utilizing a predefined switching sequence, it effectively reduces circulating current and implements pulse-pattern control, thereby decreasing harmonic content in the currents[19].

### 2.3 Switching Operation

**Table I. Switch state**

Output V	S <sub>arm1</sub>	S <sub>arm2</sub>	S <sub>arm3</sub>	S <sub>arm4</sub>	S <sub>arm1'</sub>	S <sub>arm2'</sub>	S <sub>arm3'</sub>	S <sub>arm4'</sub>
V7	On	On	On	On	On	on	Off	off
V6	On	On	On	On	On	Off	Off	Off
V5	On	On	On	On	Off	Off	Off	Off
V4	On	On	On	Off	On	Off	Off	Off
V3	On	On	Off	Off	On	On	Off	Off
V2	On	Off	Off	Off	On	On	On	Off
V1	Off	Off	Off	Off	On	On	On	On

the arm is currently exhibiting negative polarity. The capacitor initiates the process of releasing stored energy, and subsequently, the sub-module is inserted[23]. *In mode d*, when armS1 is in the open position, armS2 is in the closed position, and the arm has a negative polarity. The current moves in the direction of the subsequent module, maintaining a constant charge on the capacitor. Following this, the sub-module is bypassed[24]-[25].

### 3. RESULTS AND DISCUSSION

The control approach for the MMC is simulated using the MATLAB 2018b software package. *Table II* displays the system parameters. Various simulation scenarios are analyzed to evaluate the dynamic behavior of the proposed control approach for the Modular Multilevel Converter (MMC) under varied operational circumstances.

**Table II. System Parameters**

Input DC Voltage	218
Input DC Current	0.14
THD	10.64%

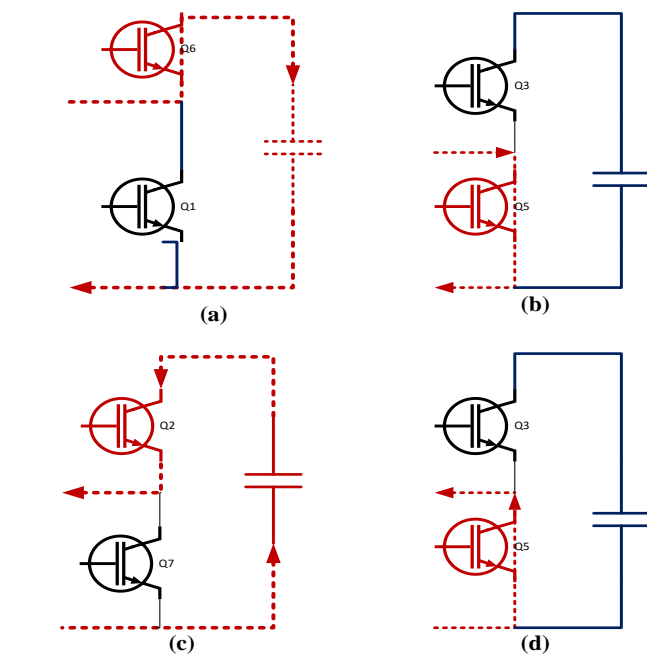

**Figure 4.** switching operation of MMC

The diagram likely represents different operating conditions or phases of a switch in a circuit, possibly illustrating the switching sequences for a power converter. Each panel (a, b, c, d) might be depicting different states at various moments within a switching cycle. The MMC bridge circuit sub-module operates in four different modes for the transfer of energy[20].

*In mode A*, when arm section1 is in a closed position, arm section2 is in an open position, and the arm has a positive polarity. An electric current enters the capacitor, causing it to get charged. Next, the sub-module is added[21]. *In mode B*, when the arm section is opened, arm section 2 is closed, and the arm has a positive polarity. The sub-module is ignored, and the electric current is directed towards the subsequent sub-module, maintaining a steady charge on the capacitor. The sub module is subsequently removed[22]. *In mode c*, section1 is now not accessible, whereas Section2 is now accessible. Additionally,

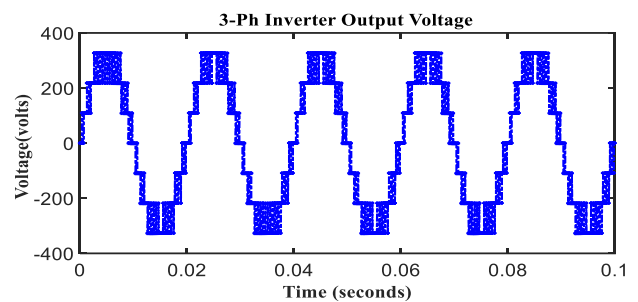

**Figure 5.** Seven Level Inverter Phase Voltage

*Figure 5* depicts, the waveform generated by a seven-level inverter consists of seven voltage levels, which allows for better output voltage quality compared to traditional two-level inverters, resulting in reduced harmonic distortion and lower switching losses. This makes them suitable for applications requiring high-quality output voltage, such as motor drives and grid-tied inverters for sustainable energy systems. The *figure5* represents three phase inverter Voltage about to 350V.

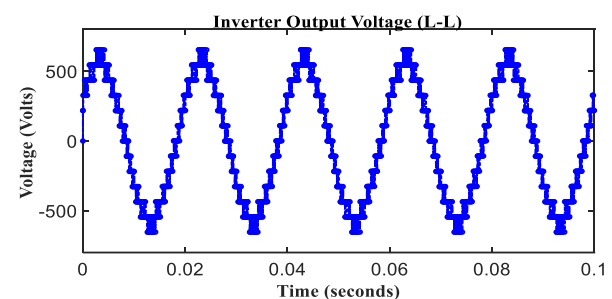

**Figure 6.** Seven Level Inverter Line Voltage

*Figure 6* depicts, the seven-level inverter's line voltage about 652V, can produce seven different voltage levels (including zero) by appropriately switching its output stages, allowing for better quality of the output waveform and potentially higher

efficiency compared to simpler inverters with fewer voltage levels.

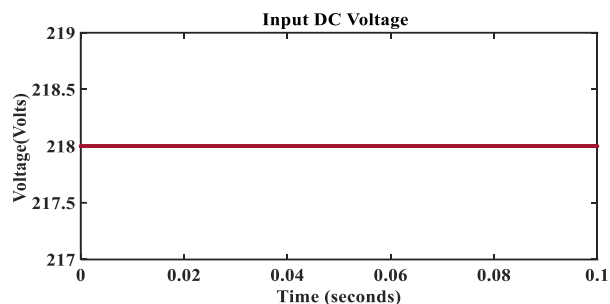

**Figure 7.** Seven Level Inverter single arm input voltage

In a single-arm seven-level inverter, the input voltage refers to the DC voltage supplied to the inverter. If the input voltage is specified as 218 volts, as shown *figure 7*. This DC voltage is then converted into various output voltage levels by the inverter's switching scheme to generate the desired AC output waveform.

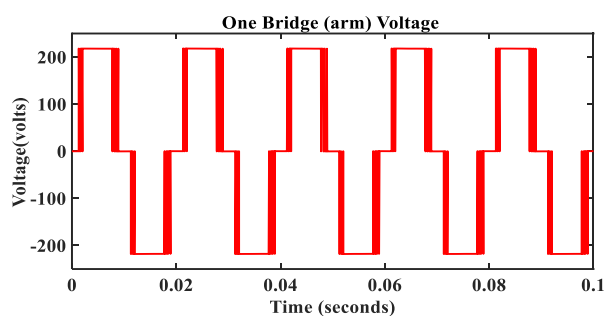

**Figure 8.** Single arm output voltage

*Figure 8* depicts single arm Bridge circuit output, which is about to 217.9V

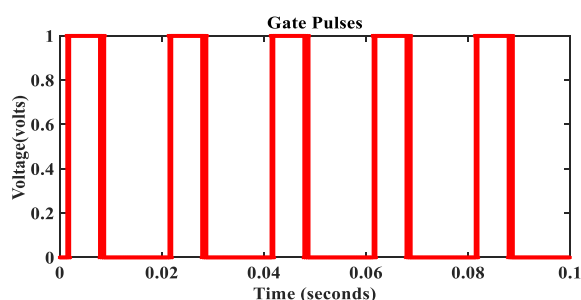

**Figure 9.** First half cycle Gate Pulses

*Figure 9* depicts gate pulses required in first half cycle. The gate pulses refer to the signals that control the switching of the semiconductor devices (such as IGBTs) to generate the desired output voltage waveform. During the first cycle of operation, the gate pulses need to be carefully synchronized and controlled to ensure that the inverter starts up correctly and generates the correct voltage levels. The exact sequence of gate pulses depends on the Model predictive control.

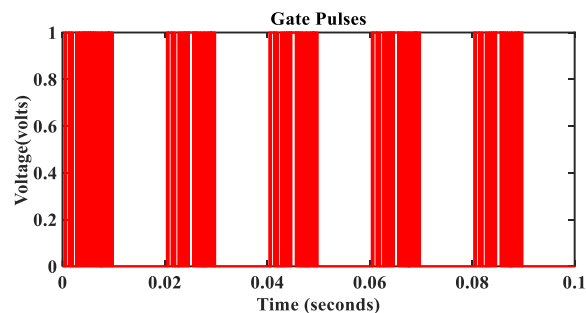

**Figure 10.** Second half cycle Gate Pulses

*Figure 10* depicts gate pulses required in second  $t$  half cycle. The gate pulses refer to the signals that control the switching of the semiconductor devices (such as IGBTs) to generate the desired output voltage waveform. During the second cycle of operation, the gate pulses need to be carefully synchronized and controlled to ensure that the inverter starts up correctly and generates the correct voltage levels. The exact sequence of gate pulses depends on the Model predictive control.

*Figure 11-12* represents rotor speed and electromagnetic torque of the motor drive. Here MMC with MPC topology helps to adjust the voltage and frequency of the supplied power to control the motor's speed and torque.

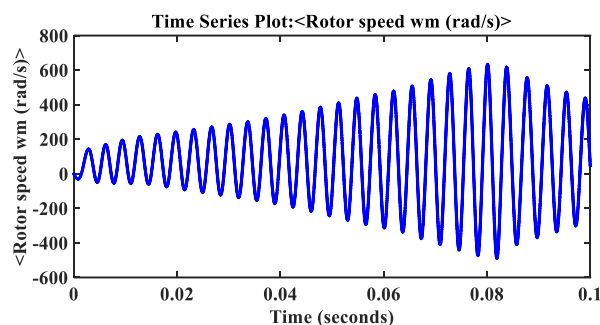

**Figure 11.** Motor Drive rotor speed

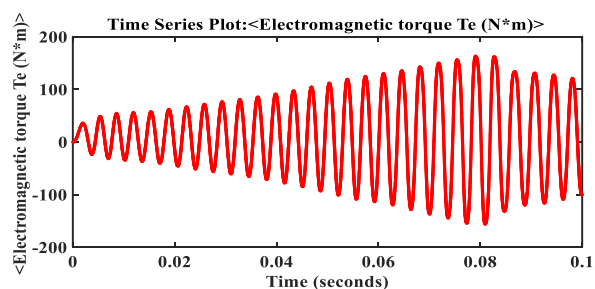

**Figure 12.** Motor Drive electromagnetic torque

*Figure 13-14* represents stator current and stator voltage of motor drive system. In which, the proposed topology addressed to the electromagnetic torque is controlled by varying the amplitude and/or phase of the current supplied to the motor windings. This torque is what drives the rotation of the motor's rotor and is a crucial parameter in determining the motor drive system's performance.

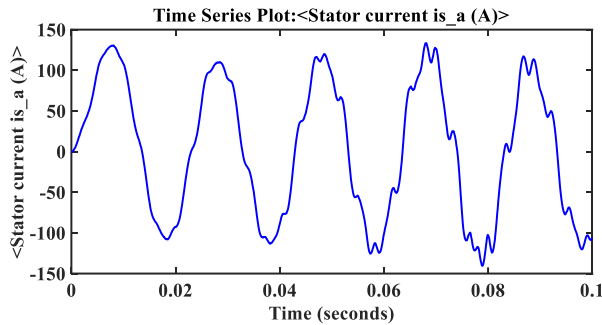
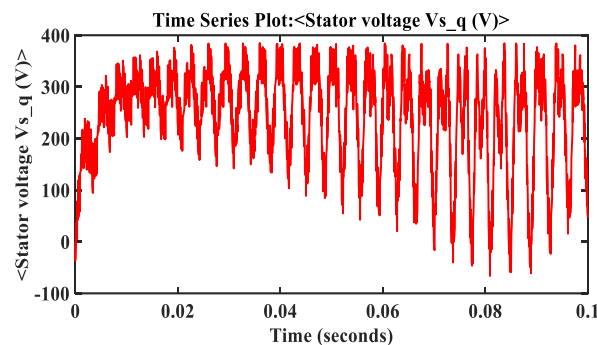
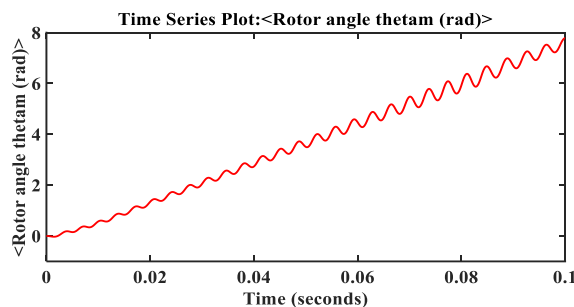

**Figure 13.** Motor Drive stator current

**Figure 14.** Motor Drive stator voltage

**Figure 15.** Motor Drive rotor angle

Figure 15 depicts rotor angle of the motor drive system. In this proposed topology, the rotor angle is essential for controlling the torque output of the motor. By adjusting the current vector's angle in the rotor reference frame, the torque produced by the motor can be controlled.

**Table III. Motor drive's specifications**

Stator phase resistance	1.6 Ohms
Inductances	$L_d=0.00636H$ , $L_q= 0.006365H$
Flux linkage	0.1852
Rotor Type	Round
Inertia	$5.5 e^{-3} lb.in.s^2$
Pole pairs	4
Back emf waveform	Sinusoidal type

## 4. CONCLUSION

The proposed topology holds great promise for enhancing motor drive system performance and reliability. Which can lead to improved performance in motor drive systems, including

higher efficiency, better dynamic response, and reduced harmonic distortion. The proposed topology helps to reduce THD in the output voltage, leading to smoother motor operation and potentially longer motor lifespan. While the initial cost of MMCs may be higher than traditional converters, their improved performance and reliability can lead to long-term cost savings.

## 5. FUTURE SCOPE

- Future developments may focus on refining Predictive Control techniques for MMCs to further improve motor control performance, including better torque and speed control.
- MMCs can be integrated with renewable energy systems, such as wind or solar, to improve grid integration and power quality.
- MMCs can play a crucial role in smart grid applications, such as grid stabilization, power factor correction, and voltage regulation.

## REFERENCES

- [1] R. Aguilar, L. Tarisciotti, and J. Pereda, "Design, Analysis and Experimental Verification of Arm Link Enhanced Modular Multilevel Converter," *IEEE J. Emerg. Sel. Top. Power Electron.*, 2024, Accessed: May 04, 2024. [Online]. Available: <https://ieeexplore.ieee.org/abstract/document/10496687/>
- [2] J. Yin, N. Dai, J. I. Leon, M. A. Perez, S. Vazquez, and L. G. Franquelo, "Common-Mode-Voltage Regulation of Modular Multilevel Converters Through Model Predictive Control," *IEEE Trans. Power Electron.*, 2024, Accessed: May 04, 2024. [Online]. Available: <https://ieeexplore.ieee.org/abstract/document/10472698/>
- [3] J. Xie, "Application of optimized photovoltaic grid-connected control system based on modular multilevel converters," *Energy Inform.*, vol. 7, no. 1, p. 24, Apr. 2024, doi: 10.1186/s42162-024-00317-3.
- [4] M. Lu, W. Han, Y. Zhao, and X. Ma, "Loss optimization for bottom IGBTs of half-bridge submodules in a high-power hybrid modular multilevel converter," *Int. J. Electr. Power Energy Syst.*, vol. 158, p. 109910, 2024.
- [5] Y. Arias-Esquivel, R. Cárdenas, M. Díaz, and L. Tarisciotti, "Continuous Control Set Model Predictive Control of a Hybrid Modular Multilevel Converter for Wind Energy Applications," *IEEE Trans. Ind. Electron.*, 2024, Accessed: May 04, 2024. [Online]. Available: <https://ieeexplore.ieee.org/abstract/document/10476721/>
- [6] J. K. Motwani, J. Liu, D. Boroyevich, R. Burgos, Z. Zhou, and D. Dong, "Modeling and Control of a Hybrid Modular Multilevel Converter for High-AC/Low-DC Medium-Voltage Applications," *IEEE Trans. Power Electron.*, 2024, Accessed: May 04, 2024. [Online]. Available: <https://ieeexplore.ieee.org/abstract/document/10433127/>
- [7] V.-T. Nguyen, J.-W. Kim, J.-W. Lee, and B.-G. Park, "Optimal Design of a Submodule Capacitor in a Modular Multilevel Converter for Medium Voltage Motor Drives," *Energies*, vol. 17, no. 2, p. 471, 2024.
- [8] J.-W. Lee, J.-W. Kim, C.-W. Lee, and B.-G. Park, "Common-Mode Voltage Reduction of Modular Multilevel Converter Using Adaptive High-Frequency Injection Method for Medium-Voltage Motor Drives," *Energies*, vol. 17, no. 6, p. 1367, 2024.
- [9] N. Namburi Nireekshana and K. R. Kumar, "A Modern Distribution Power Flow Controller with A PID-Fuzzy Approach: Improves the Power Quality", Accessed: Apr. 25, 2024. [Online]. Available: <https://ijeer.forexjournal.co.in/papers-pdf/ijeer-120124.pdf>

[10] N. Nireekshana, "Control of a Bidirectional Converter to Interface Electrochemical double layer capacitors with Renewable Energy Sources", Accessed: Dec. 15, 2023. [Online]. Available: <https://scholar.archive.org/work/hy45tgegmjdiqqou4wxqqr5m/access/wayback/>

[11] Namburi Nireekshana, Tanvi H Nerlekar, P. N. Kumar, and M. M. Bajaber, "An Innovative Solar Based Robotic Floor Cleaner," May 2023, doi: 10.5281/ZENODO.7918621.

[12] Namburi Nireekshana, M. Anil Goud, R. Bhavani Shankar, and G. Nitin Sai Chandra, "Solar Powered Multipurpose Agriculture Robot," May 2023, doi: 10.5281/ZENODO.7940166.

[13] N. Nireekshana, "Reactive Power Compensation in High Power Applications by Bidirectional cascaded H-Bridge Based Statcom".

[14] N. Nireekshana, R. Ramachandran, and G. V. Narayana, "A Novel Swarm Approach for Regulating Load Frequency in Two-Area Energy Systems," *Int. J. Electr. Electron. Res.*, vol. 11, no. 2, pp. 371–377, Jun. 2023, doi: 10.37391/ijeer.110218.

[15] N. Nireekshana, R. Ramachandran, and G. V. Narayana, "A New Soft Computing Fuzzy Logic Frequency Regulation Scheme for Two Area Hybrid Power Systems," *Int. J. Electr. Electron. Res.*, vol. 11, no. 3, pp. 705–710, Aug. 2023, doi: 10.37391/IJEER.110310.

[16] N. Nireekshana, R. Ramachandran, and G. V. Narayana, "Novel Intelligence ANFIS Technique for Two-Area Hybrid Power System's Load Frequency Regulation," *E3S Web Conf.*, vol. 472, p. 02005, 2024, doi: 10.1051/e3sconf/202447202005.

[17] S. Ou *et al.*, "A Data-Driven Condition Monitoring Method for Capacitor in Modular Multilevel Converter (MMC)." arXiv, Apr. 20, 2024. Accessed: May 04, 2024. [Online]. Available: <http://arxiv.org/abs/2404.13399>.

[18] M. Li, X. Jiang, C. Chen, K. Zhang, and J. Xiong, "Fault-Tolerant Strategy for Modular Multilevel Converters with Combined Zero-Sequence Voltage Injection," *IEEE Trans. Power Electron.*, 2024, Accessed: May 04, 2024. [Online]. Available: <https://ieeexplore.ieee.org/abstract/document/10505000/>

[19] V. D. R. Dreke, Y. P. Marca, M. Roes, and M. Lazar, "Multivariable control of modular multilevel converters with convergence and safety guarantees." arXiv, Mar. 27, 2024. Accessed: May 04, 2024. [Online]. Available: <http://arxiv.org/abs/2403.18371>

[20] L. Liao, X. Hu, H. Li, S. Sun, and J. Jiang, "Design of an improved modular multilevel converter reconfigurable equalization scheme based on difference of voltage variation," *J. Electrochem. Energy Convers. Storage*, vol. 21, no. 3, 2024, Accessed: May 04, 2024. [Online]. Available: <https://asmedigitalcollection.asme.org/electrochemical/article/21/3/031010/1169606>

[21] G. Jia, M. Li, L. Chen, B. Shi, F. Niu, and Y. Tang, "A modular multilevel converter with active power filter (APF-MMC) under low-frequency operation," *J. Power Electron.*, vol. 24, no. 5, pp. 721–733, May 2024, doi: 10.1007/s43236-023-00764-3.

[22] D. A. Ganeshpure, T. B. Soeiro, M. G. Niasar, N. M. Kulkarni, P. Bauer, and P. Vaessen, "Design of Integrated Hybrid Configuration of Modular Multilevel Converter and Marx Generator to Generate Complex Waveforms for Dielectric Testing of Grid Assets," *IEEE Open J. Ind. Electron. Soc.*, vol. 5, pp. 170–184, 2024.

[23] Q. Li, B. Li, Z. Xie, and B. Zhou, "Multi-objective optimization of circulating current control considering operating conditions of modular multilevel converter," *Int. J. Electr. Power Energy Syst.*, vol. 155, p. 109474, 2024.

[24] R. Ganji and J. Singh, "A modified modular multilevel converter to reduce the second order ripples in the submodule capacitor voltage: Design and analysis," *Int. J. Circuit Theory Appl.*, p. cta.3908, Jan. 2024, doi: 10.1002/cta.3908.

[25] T. Salvadores, J. Pereda, and F. Rojas, "Power Imbalance Analysis of Modular Multilevel Converter with Distributed Energy Systems," *IEEE Open J. Ind. Electron. Soc.*, 2024, Accessed: May 04, 2024. [Online]. Available: <https://ieeexplore.ieee.org/abstract/document/10433267/>



© 2024 by Kishor Parapelly, C. Mahalakshmi, Venu Madhav G. Submitted for possible open access publication under the terms and conditions of the Creative Commons Attribution (CC BY) license (<http://creativecommons.org/licenses/by/4.0/>).